

This is a general specification leaflet; for specific applications not covered herein, contact Suntec.

The SUNTEC **AS** oil pump has a built in solenoid valve which controls the regulator cut-off valve giving fast cut-off and cut-on function independent of the rotational speed.

APPLICATIONS

- Light oil, B10 heating oil/biofuel blend (as defined in DIN V51603-6) and kerosene.
- One or two-pipe system.

PUMP OPERATING PRINCIPLE

The gear set draws oil from the tank through the built-in filter and transfers it to the valve that regulates the oil pressure to the nozzle line. All oil that does not go through the nozzle line will be dumped through the valve back to the return line in two pipe installation or, if it is a one-pipe installation, back to suction port in the gear set. In that case, the by-pass plug must be removed from the return port, and the return port sealed by steel plug and washer.

The solenoid valve of the AS pump is of the "normally opened" type.

When the solenoid valve is non-activated, the by-pass channel between the pressure and return sides of the valve is open. No pressure will then be built up to open the valve; it does not matter which speed the gear set has.

When the solenoid is activated, this by-pass channel is closed and because of the full speed of the gear set, the pressure necessary to open the valve will be built up very rapidly, which gives a very sharp cut-on function.

Cut-off :

When the burner stops, the solenoid opens the by-pass at the same moment, which drains all the oil down to the return, and the nozzle valve closes immediately. This gives a very sharp cut-off function.

The cut-on and cut-off can be actuated regardless of motor speed and have an extremely fast response.

When the solenoid is not activated, the torque requirement is low up to full motor speed.

Bleed :

Bleeding in two pipe operation is automatic, but it may be accelerated by opening a pressure port.

In one pipe operation, a pressure port must be opened to bleed the system.

PUMP IDENTIFICATION

(Not all model combinations are available. Consult your Suntec representative)

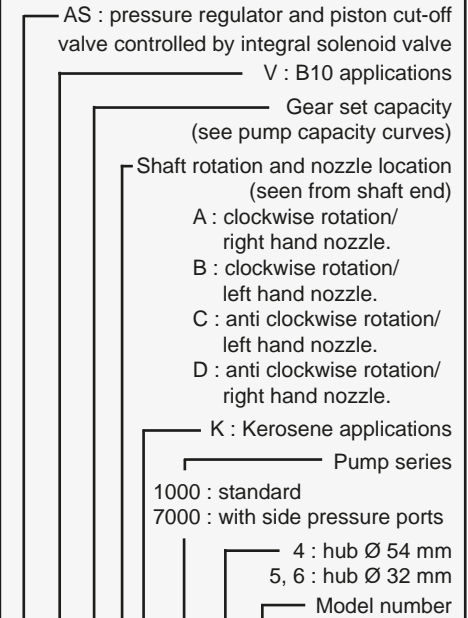

AS V 47 C K 1 5 xx 6 P 07 00

Revision number _____

Installation _____

Solenoid coil voltage _____

Connector cable length _____

00 : no cable		
35 : 35 cm	-	45 : 45 cm
60 : 60 cm	-	10 : 1 m

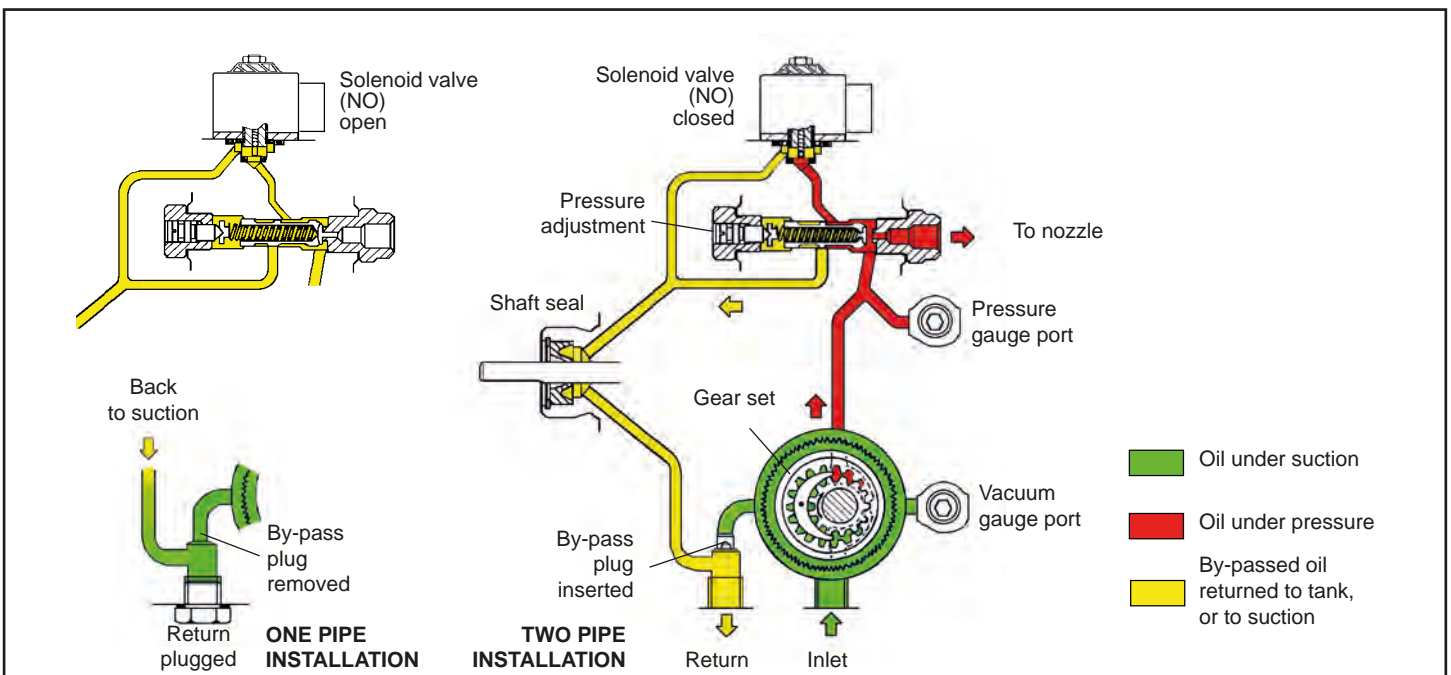

TECHNICAL DATA

General

Mounting	Flange or hub mounting according to EN 225.
Connection threads	cylindrical according to ISO 228/1.
Inlet and return	G 1/4 (with facilities for conical sealing on revision 6)
Nozzle outlet	G 1/8
Pressure gauge ports	G 1/8
Vacuum gauge port	G 1/8
Valve function	Pressure regulation and cut-off*.
*cut-off function only assured for model pressure range.	
Strainer	open area : 6 cm ² - opening size : 150 µm.
Shaft	Ø 8 mm according to European standard EN 225.
By-pass plug	inserted in return port for two-pipe system ; to be removed with a 4 mm Allen key for one pipe system.
Weight	1,1- 1,5 kg (depending on the model).

Hydraulic Data

Gear size	Nozzle pressure range*	Factory setting
20/47	7 - 14 or 7-25 bars @ 5 cSt	9 or 10 bars
57	7 - 14 bars @ 5 cSt	9 bars
67	10 - 15 bars @ 5 cSt	10 bars
47K/57K	7 - 14 bars @ 1,8 cSt	9 bars
67K	10 - 15 bars @ 1,8 cSt	10 bars

* other ranges available on request, refer to the specified range of the particular fuel unit.

Operating viscosity	2 - 12 mm ² /s (cSt) for AS 20/47/57/67 1,25 - 12 mm ² /s (cSt) for AS 47K/57K/67K
Oil temperature	0 - 60°C in the pump.
Inlet pressure	2 bars max.
Return pressure	2 bars max.
Suction height	0,45 bars max. vacuum to prevent air separation from oil.
Rated speed	3600 rpm max. for AS 20/47/47K/57/57K 2850 rpm max for AS 67/67K
Torque (@ 45 rpm)	0,09 for AS 20 0,10 N.m for AS 47/47K/57/57K 0,12 N.m for AS 67/67K

Solenoid valve characteristics

Voltage	220-240 or 110-120 or 24 V; 50/60 Hz.
Consumption	9 W max.
Coil Code*	Ambient temperature
06/02/05	0 - 60 °C
07	0 - 80 °C

* Refer to "Pump identification - solenoid coil voltage".

Maximum pressure	25 bars
Certified	TÜV Nr. stamped on pump cover.
Protection class	IP 54 according to EN 60529, when used with SUNTEC connector cable.

Pump capacity

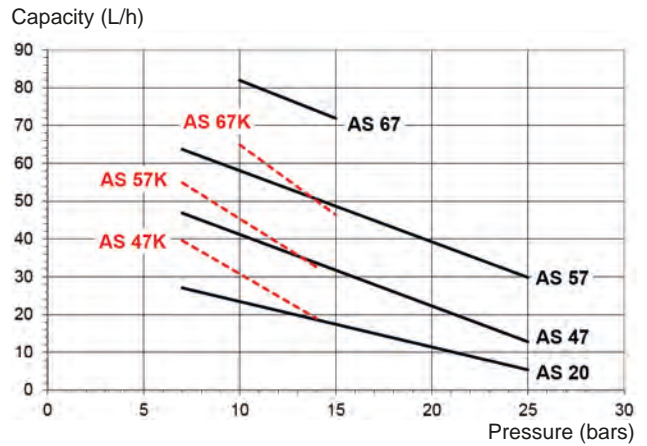

Data shown take into account a wear margin.
Do not oversize the pump when selecting the gear capacity.

Power consumption

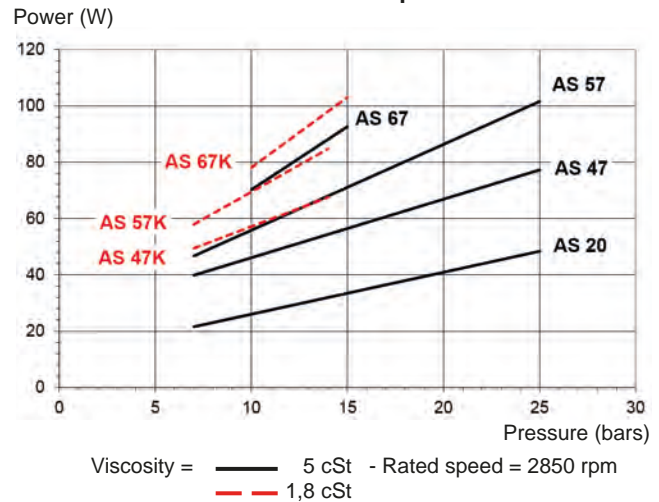

PUMP DIMENSIONS

Examples show "C" rotation and nozzle outlet.

Pumps revision 6

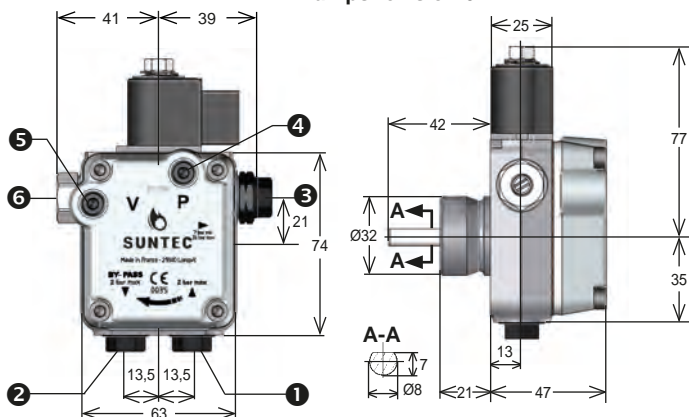

Pumps revision 4

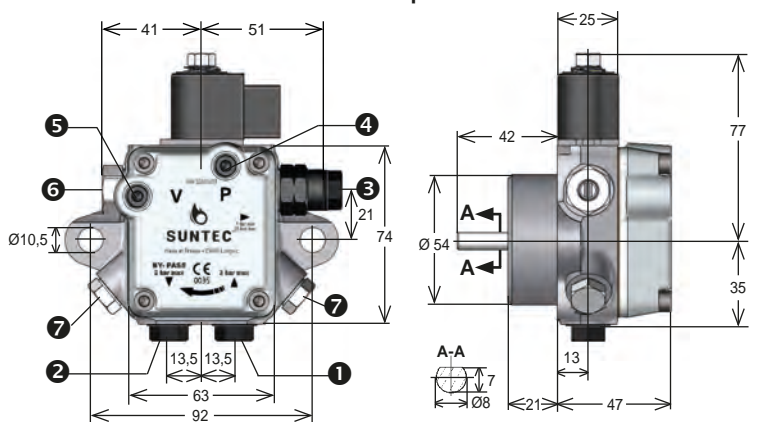

Inlet ① and Return ② with direct sealing for revision 6 (sealing with washers can also be used)

- ① Suction
- ② Return and internal by-pass plug
- ③ Nozzle outlet
- ④ Pressure gauge port
- ⑤ Vacuum gauge port
- ⑥ Pressure adjustment
- ⑦ Pressure port (only for "7000" series)